

eduard

LIMITED EDITION
DUAL COMBO



Trenér

INSTRUCTION SHEET

1/48

11152-NAV1



Carefully read instruction sheet before assembling. When you use glue or paint, do not use near open flame and use in well ventilated room. Keep out of reach of small children. Children must not be allowed to suck any part, or pull vinyl bag over the head.



Před započatím stavby si pečlivě prostudujte stavební návod. Při používání barev a lepidel pracujte v dobře větrané místnosti. Lepidla ani barvy nepoužívejte v blízkosti otevřeného ohně. Model není určen malým dětem, mohlo by dojít k požití drobných dílů.

INSTRUCTION SIGNS * INSTR. SYMBOLS * INSTRUKTION SINNBILDEN * SYMBOLES * 記号の説明

OPTIONAL
VOLBABEND
OHNOUTSAND
BROUSITOPEN HOLE
VYVRTAT OTVORSYMETRICAL ASSEMBLY
SYMETRICKÁ MONTÁŽREMOVE
ODŘÍZNOUTREVERSE SIDE
OTOČITAPPLY EDUARD MASK
AND PAINT
POUŽIT EDUARD MASK
NABARVIT

PARTS



DÍLY



TEILE



PIÈCES



部品

PLASTIC PARTS

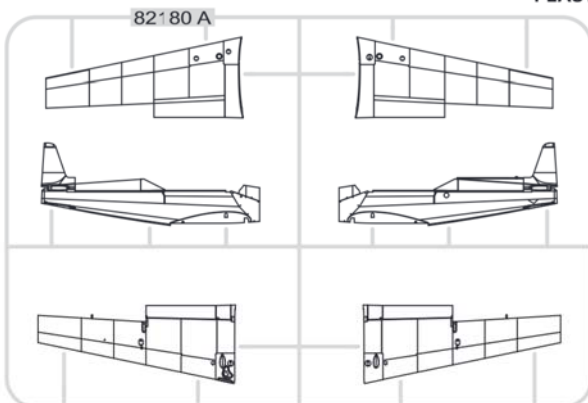
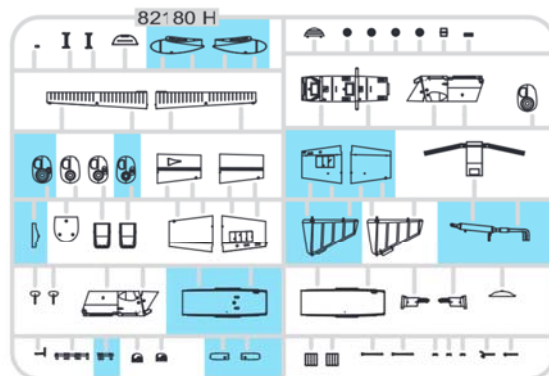
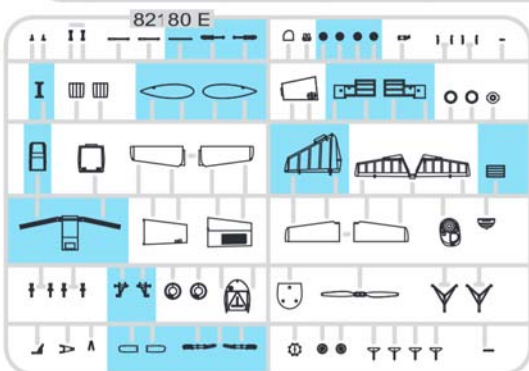
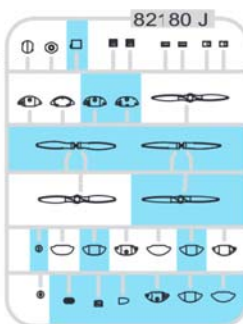
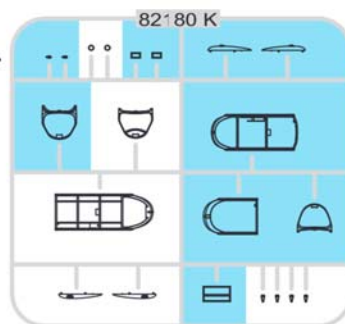
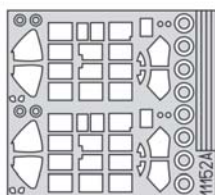
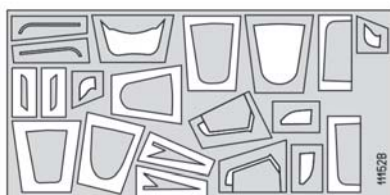
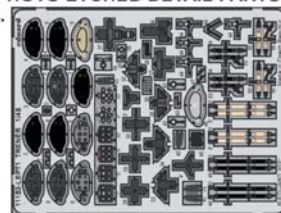
A>
2 pcs.H>
2 pcs.E>
2 pcs.J>
2 pcs.K>
2 pcs.eduard
MASKPE - PHOTO ETCHED DETAIL PARTS
2 pcs.

-Parts not for use. -Teile werden nicht verwendet. -Pièces à ne pas utiliser. -Tyto díly nepoužívejte při stavbě. - 使用しない部品

COLOURS



BARVY



FARBEN



PEINTURE



色

GSI Creos (GUNZE)		MISSION MODELS	
AQUEOUS	Mr.COLOR	PAINTS	
H1	C1	MMP-001	WHITE
H2	C2	MMP-047	BLACK
H3	C3	MMP-003	RED
H4	C4	MMP-007	YELLOW
H5	C5	MMP-048	BLUE
H6	C6	MMP-004	GREEN
H7	C7	MMP-002	BROWN
H8	C8		SILVER
H12	C33	MMP-047	FLAT BLACK
H15	C65		BRIGHT BLUE
H24	C58		ORANGE YELLOW
H25	C34		SKY BLUE
H33	C81		RUSSET
H37	C43		WOOD BROWN
H57	C73		AIRCRAFT GRAY
H66	C119	MMP-119	RLM79 SAND YELLOW
H70	C60	MMP-056	RLM02 GRAY
H77	C137	MMP-040	TIRE BLACK
H85	C45		SAIL COLOR
H90	C47		CLEAR RED

GSI Creos (GUNZE)		MISSION MODELS	
AQUEOUS	Mr.COLOR	PAINTS	
H94	C138		CLEAR GREEN
H301	C301	MMP-099	GRAY
H306	C306	MMP-118	MEDIUM GRAY
H308	C308	MMP-073	GRAY
H317	C317	MMP-064	GRAY
H323	C323	MMP-092	LIGHT BLUE
H329	C329	MMP-041	YELLOW
H334	C334	MMP-102	BARLEY GRAY
H362	C362		OCEAN GRAY
H363	C363		MEDIUM SEAGRAY
H364	C364		GRAY GREEN
H413	C113	MMP-090	RLM04 YELLOW
	C25		DARK SEAGRAY
	C74	MMP-061	AIR SUPERIORITY BLUE
Mr.METAL COLOR		METALLICS	
MC214		MMM-001	DARK IRON
MC217			GOLD
MC218		MMM-003	ALUMINIUM
Mr.COLOR SUPER METALLIC		METALLICS	
SM201		MMC-001	SUPER FINE SILVER 2

A MARKINGS **A, A₁**

PE41 ⤴
PE32 ⤴
PE10 ⤴
PE31 ⤴

MARKING **B**

PE37 ⤴
PE39 ⤴

MARKING **C**

PE27 ⤴

MARKINGS **D, F, G, J**

PE41 ⤴
PE32 ⤴
PE31 ⤴

MARKING **E**

PE29 ⤴
PE35 ⤴

MARKING **H**

PE30 ⤴
PE34 ⤴

MARKING **I**

PE28 ⤴
PE33 ⤴

C MARKINGS **A, E, F, G, J**

H50
E5
E28
H52
H15
H11
fill
A
B

B E45
E13
H16
H12
PE38

PE44 ⤴
E14
H15

PE44 ⤴
E14
H15

H3
MMP
C3 003
RED

H4
MMP
C4 007
YELLOW

H7
MMP
C7 002
BROWN

H8
C8
SILVER

H36

H36

MARKINGS **B, C, D, H, I**

H50
E5
E28
H52
H53
H15
H11
B

H16
H12
PE36
PE38
PE36 - MARKING **C** ONLY

H3
MMP
C3 003
RED

H4
MMP
C4 007
YELLOW

H7
MMP
C7 002
BROWN

H8
C8
SILVER

H36

PE44 ⤴
E14
H15

PE44 ⤴
E14
H15

PE44 ⤴
E14
H15

PE44 ⤴
E14
H15

H36

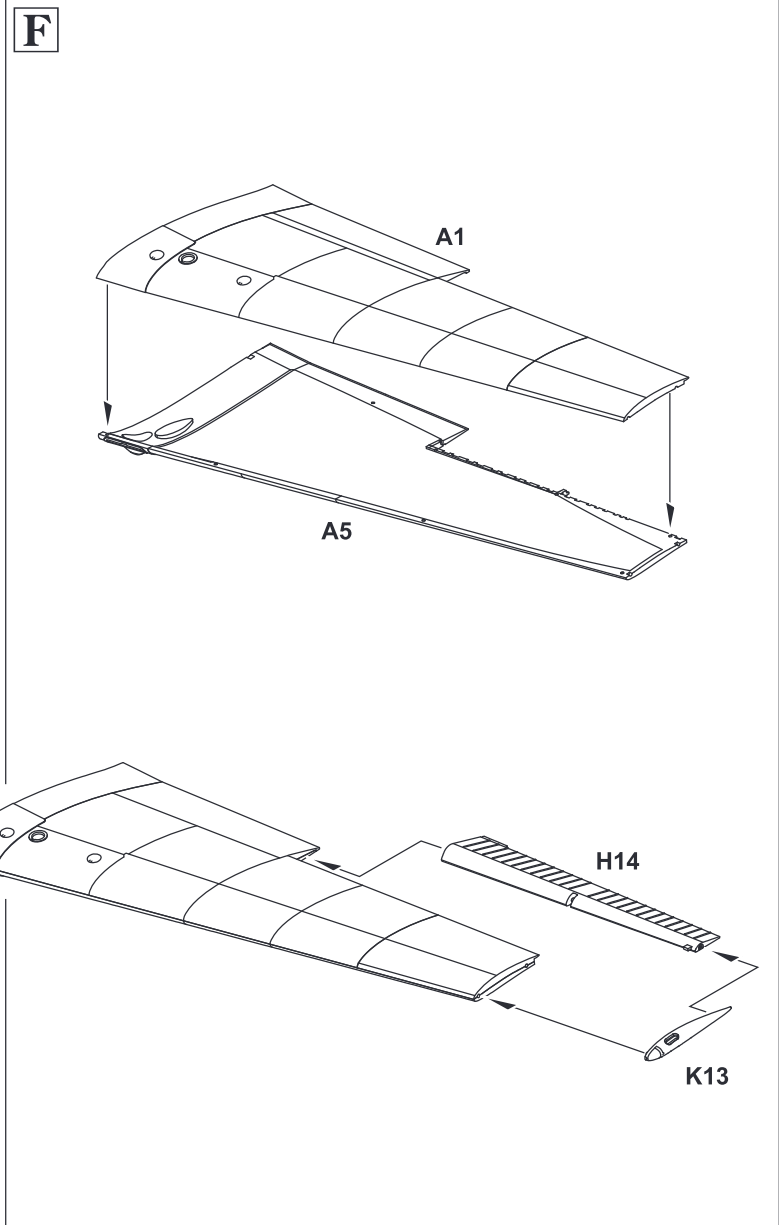
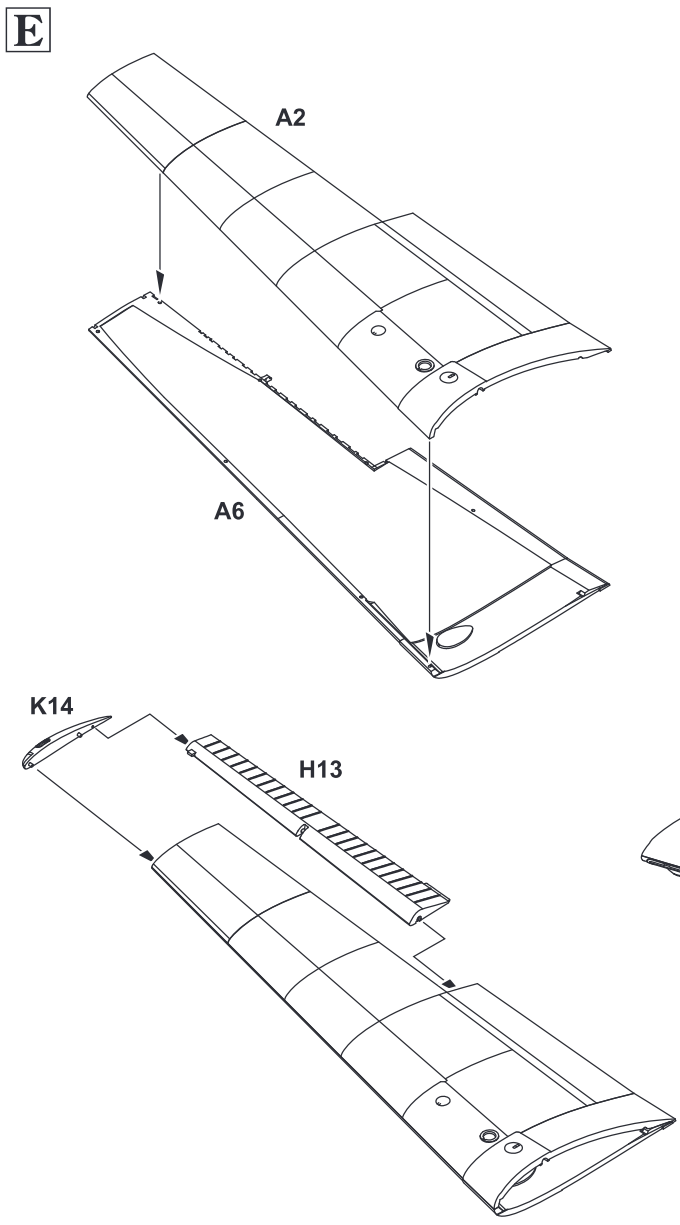
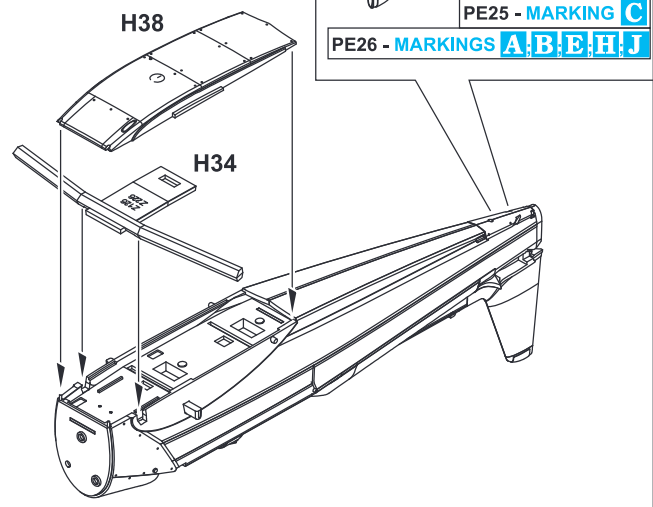
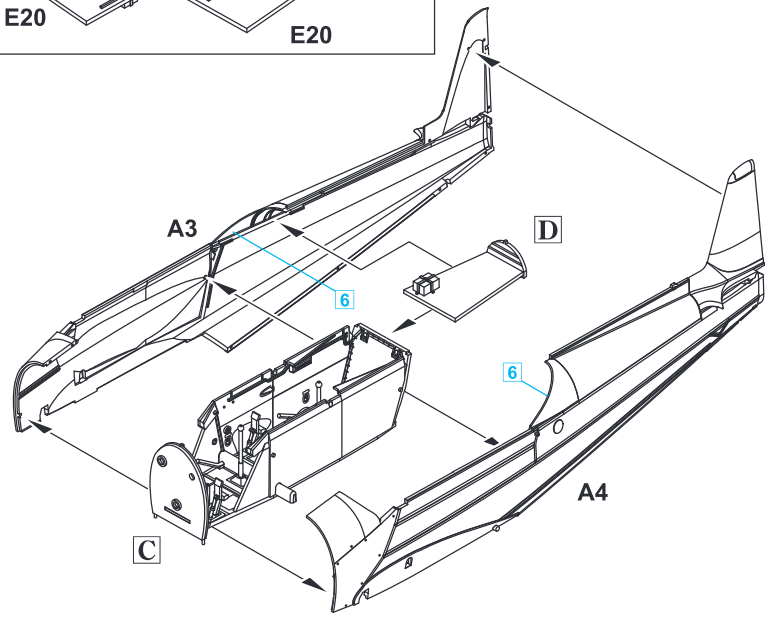
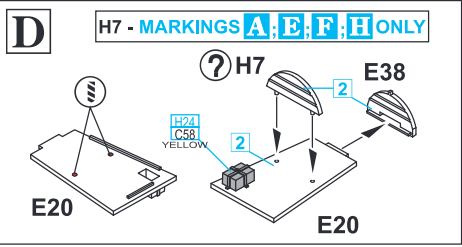

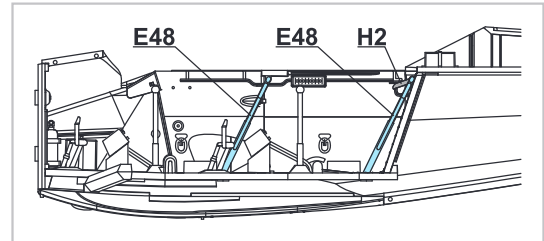
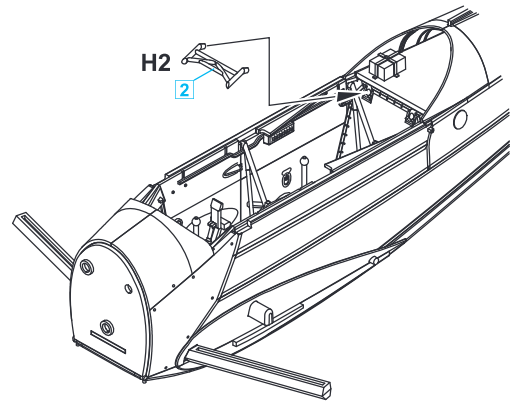
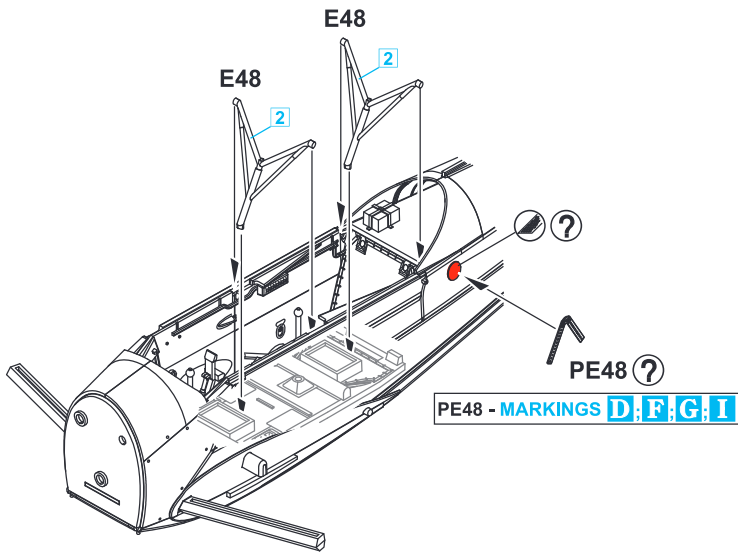

G MARKINGS B, C, D, H, I

K16 - MARKINGS B, I



MARKINGS A, E, F, G, J

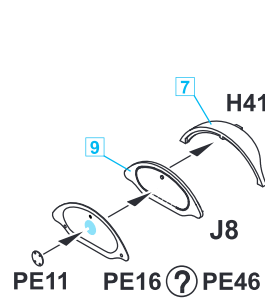
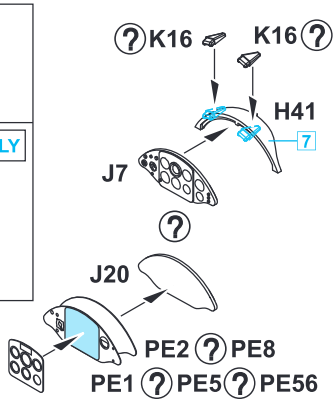

PE16 - MARKINGS E, F
PE11, 46 - MARKINGS A, G, J

PE17 ? PE19 ? PE21
PE1, 2, 17 - MARKINGS B, D, I
PE2, 6, 21 - MARKING H
PE5, 8, 19 - MARKING C

H

K16 - MARKINGS A, B, E, F, I, J

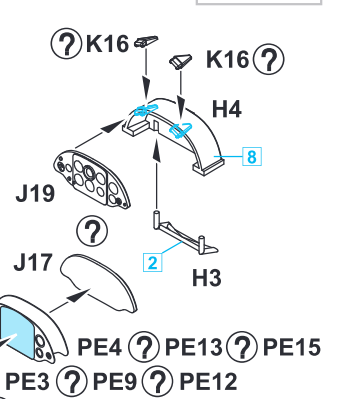
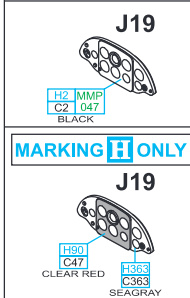
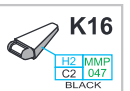

PE3, 4, 18 - MARKINGS A, B, D, E, F, G, I, J
PE9, 13, 22 - MARKING H
PE12, 15, 20 - MARKING C

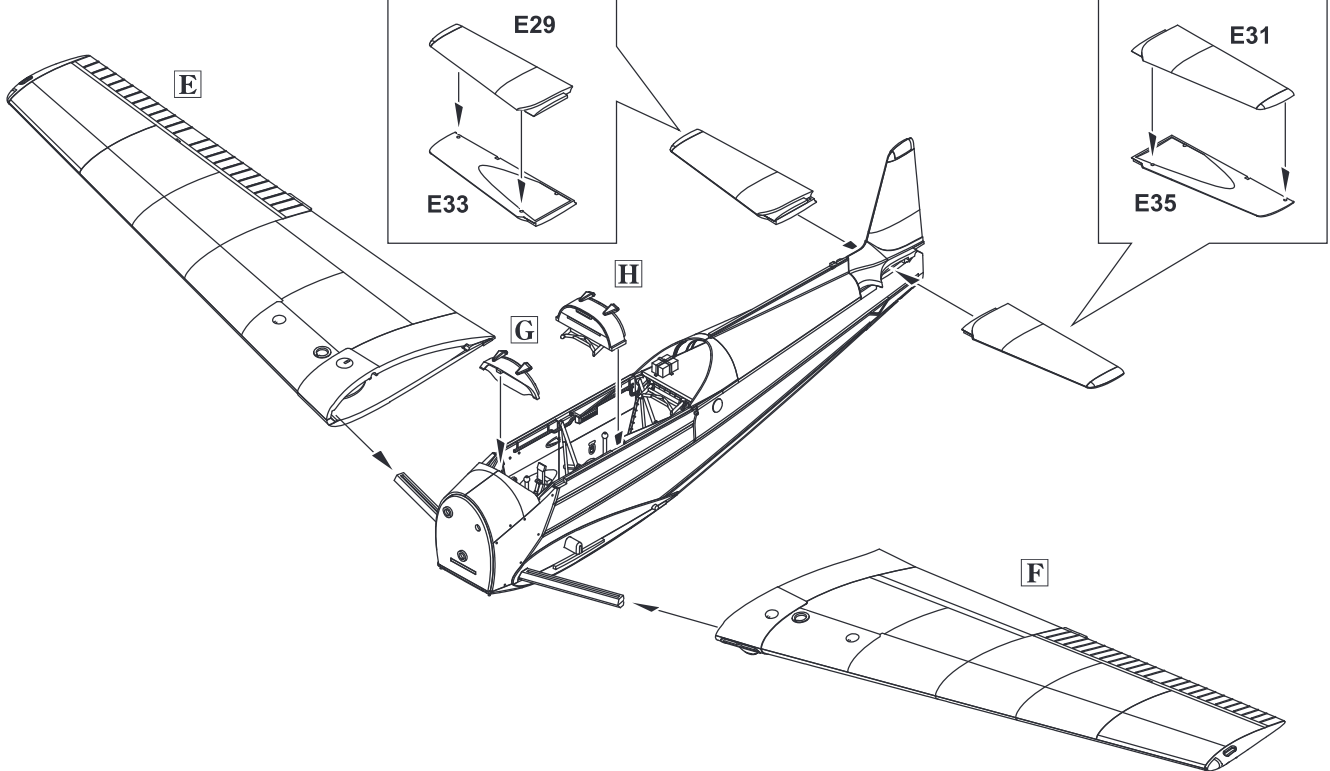

I MARKINGS **A, B, E, H, I, J**

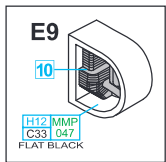

E37

E9

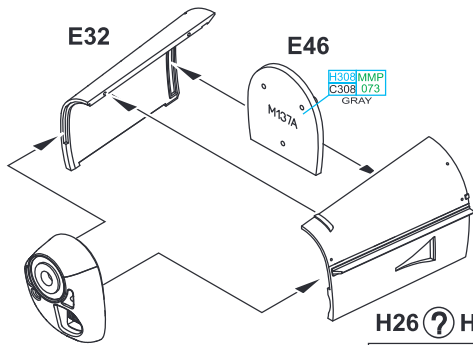

H26 ? H27

H26 - MARKINGS **A, B, H, J**

H27 - MARKINGS **A, E, I**

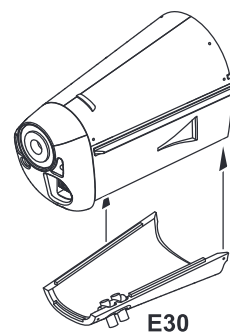

E30

MARKINGS **C, D, F, G**

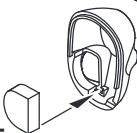
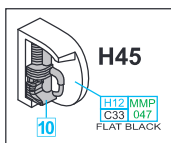

H45



H21 ? H22

H21, PE45 - MARKINGS **C, F**

H22 - MARKING **G, D**

H28

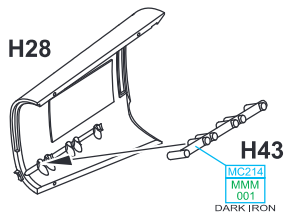

H43

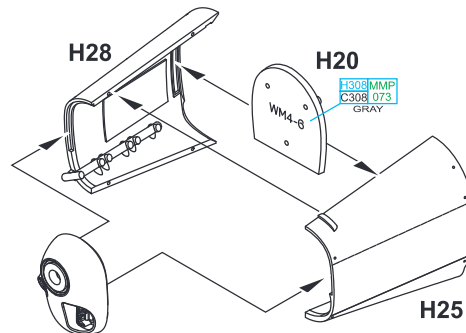

H25

2 pcs.

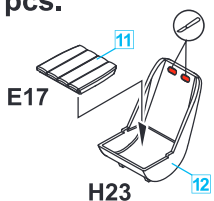

H23

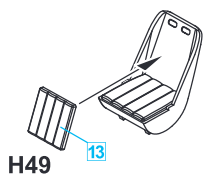

H49

REAR SEAT

PE54 ? PE55

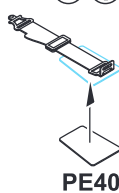

PE40

PE53 ? PE56

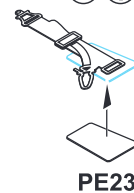

PE23

MARKING **I** ONLY

FRONT SEAT



H23

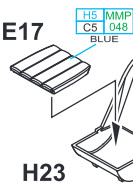

H23

PE49 ? PE51
PE50 ? PE52

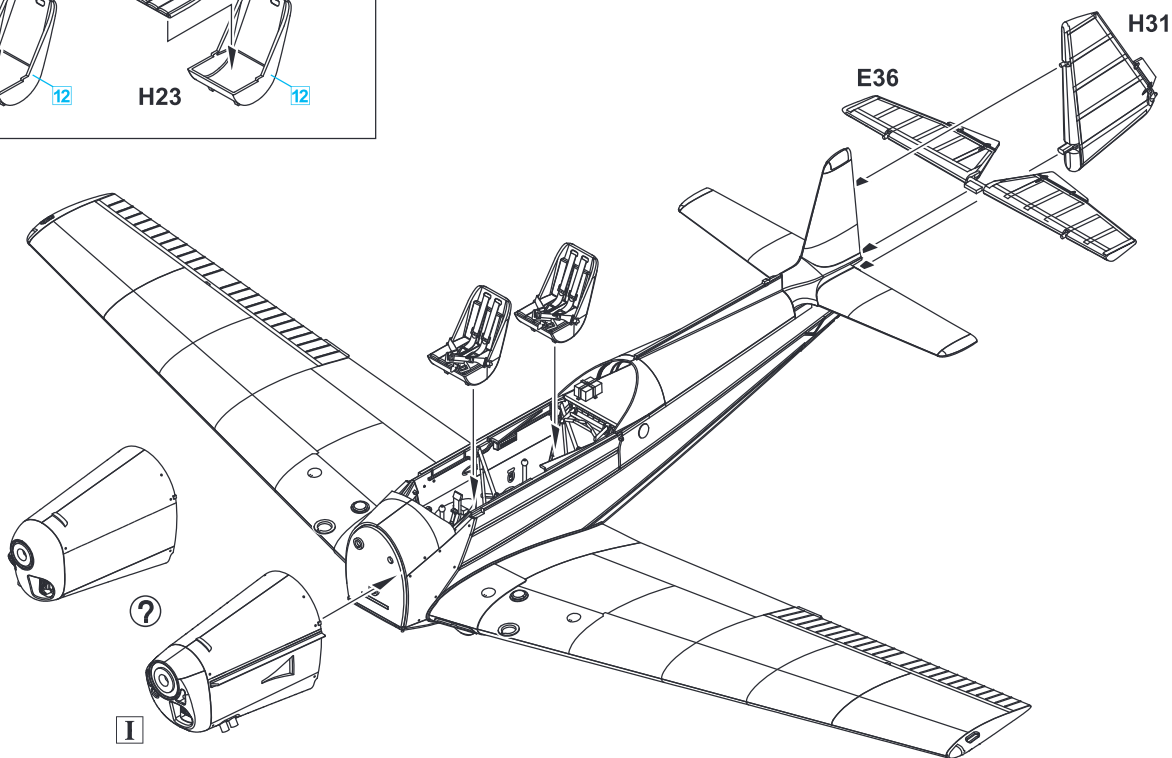

?

I

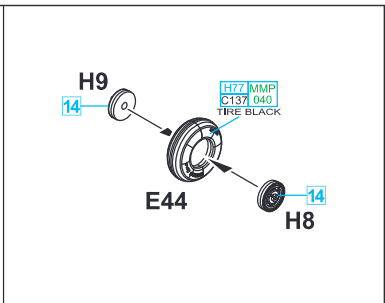
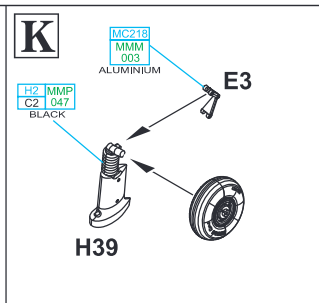
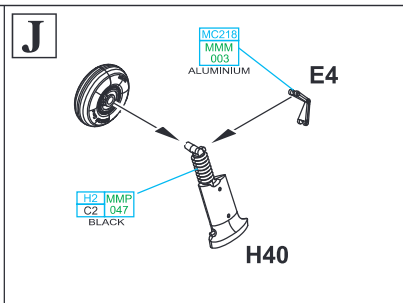
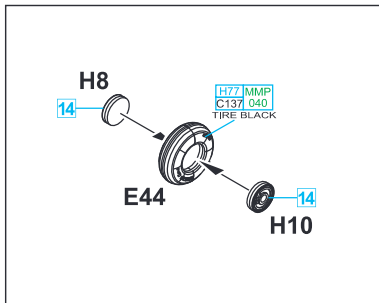

E59 - MARKINGS A H I **H35 - MARKINGS B C D E F G J** **L** **M**

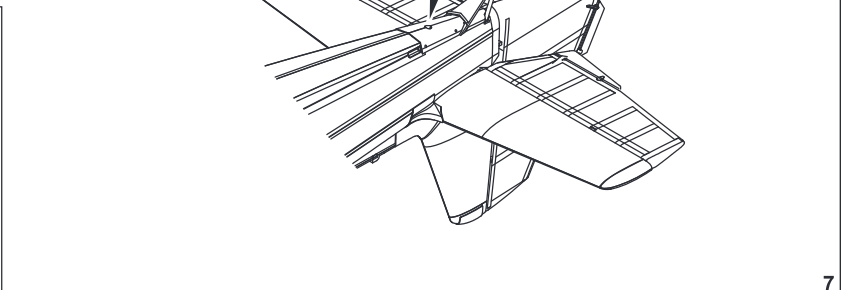
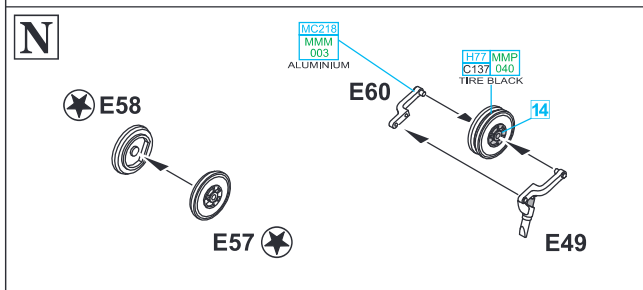
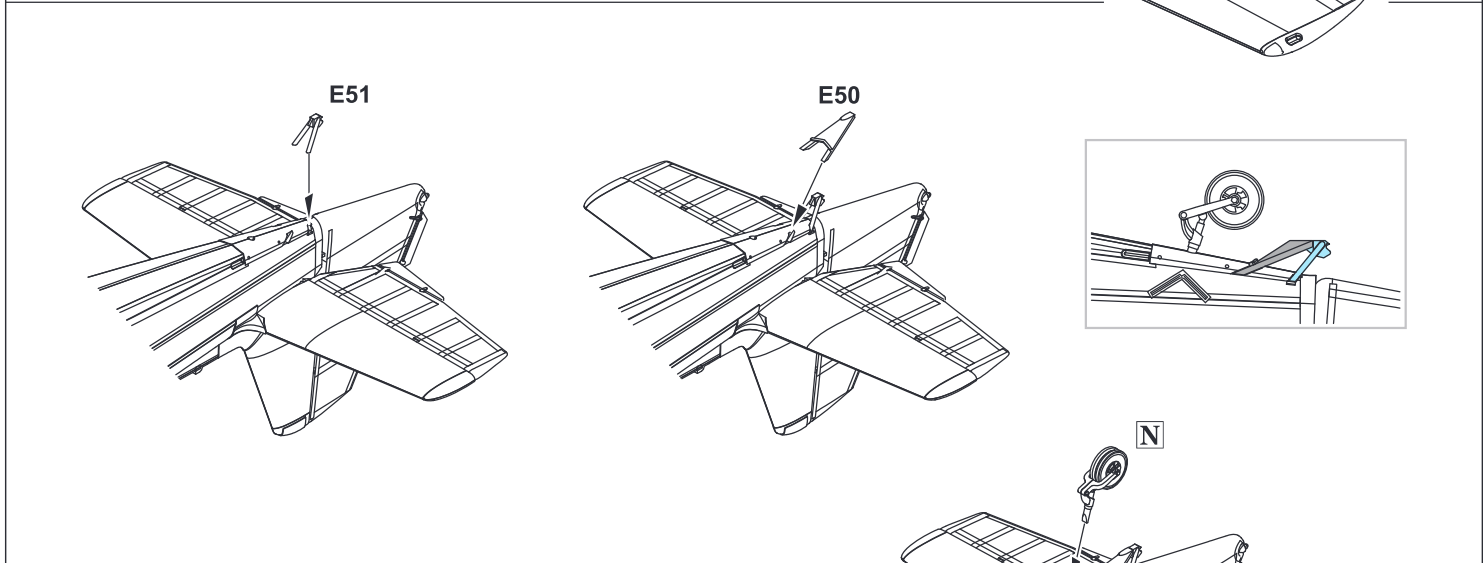
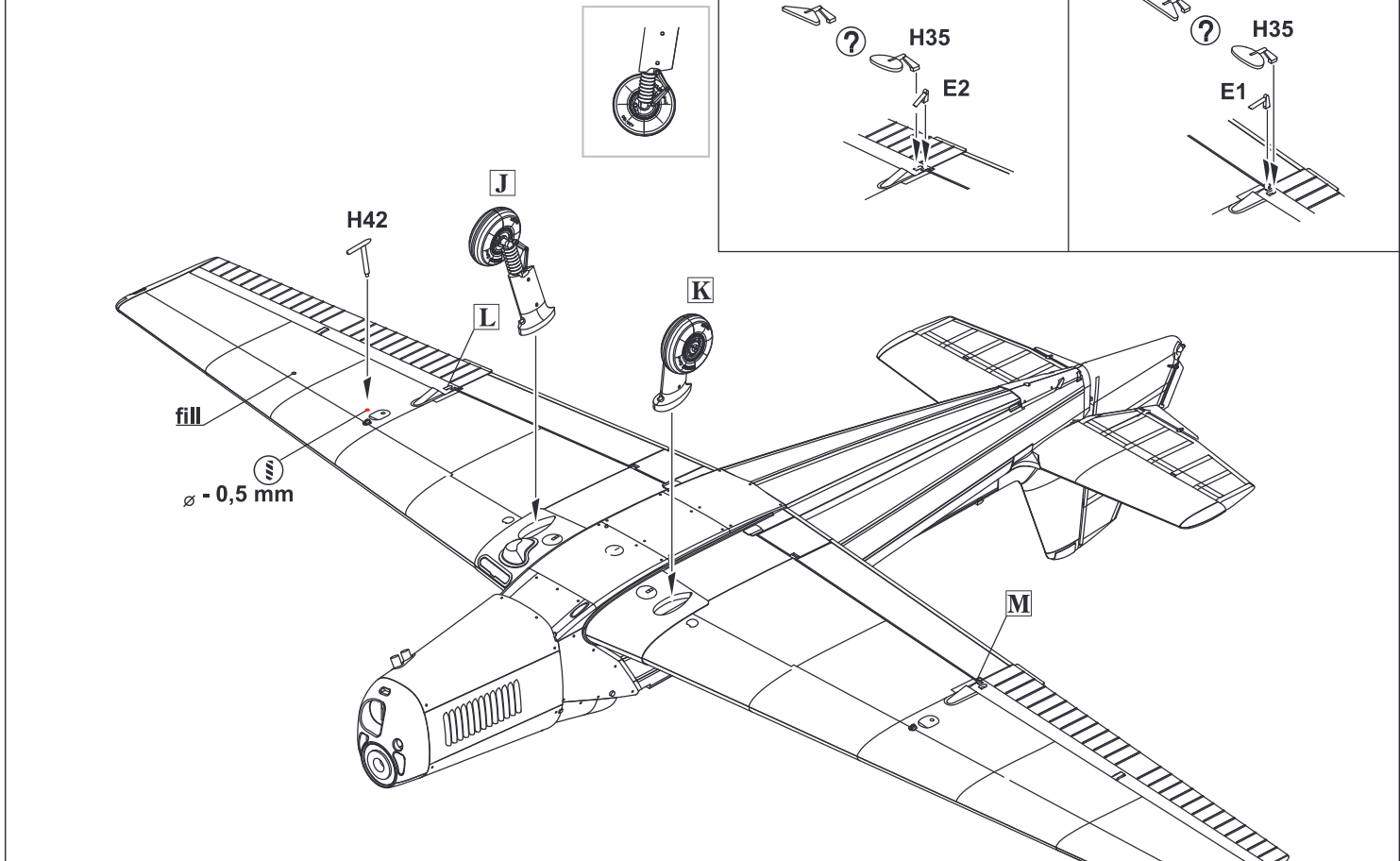

O MARKINGS **A, B, H, I, J**

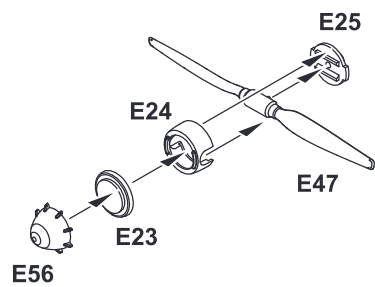

P

PLASTIC ROD
 $\varnothing = 1,8 \text{ mm}$
 $L = 2 \text{ mm}$

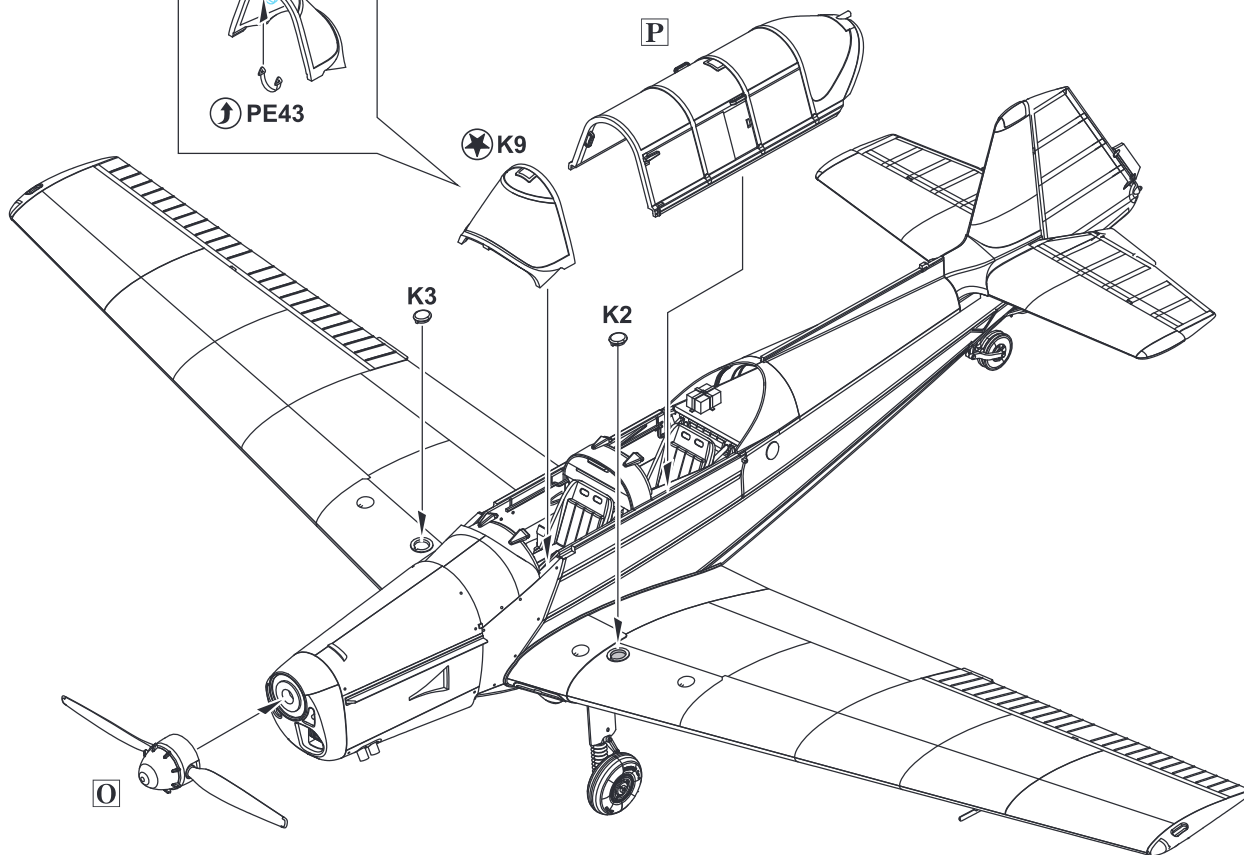
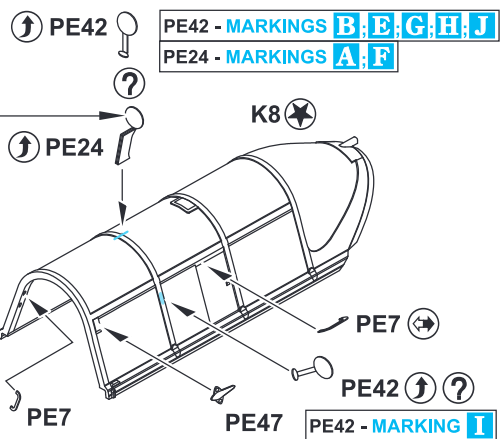
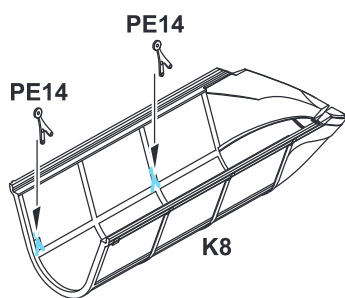

?

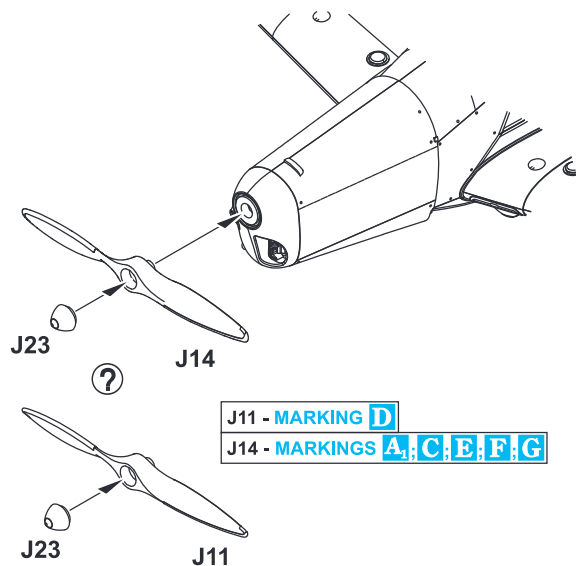

OPEN CANOPY

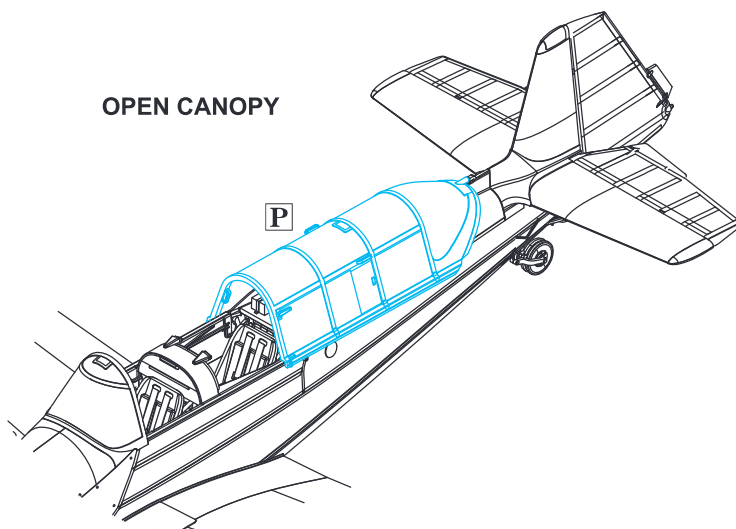

<p>1 = - MARKINGS C, G - MARKINGS A, B, D, E, F, I - MARKING H</p>	<p>2 = - MARKING A - MARKINGS B, D, E, F, G, I, J - MARKING C - MARKING H</p>	<p>3 = - MARKINGS A, B, D, E, F, G, I, J - MARKINGS C, H</p>
<p>4 = - MARKING A - MARKINGS B, C, D, E, F, G, I, J - MARKING H</p>	<p>5 = - MARKING C - MARKINGS A, H - MARKINGS B, D, E, F, G, I, J</p>	<p>6 = - MARKINGS H, I - MARKINGS A, B, D, F, G, J - MARKING E - MARKING C</p>
<p>7 = - MARKINGS A, B, C, D, E, F, G, I, J - MARKING H</p>	<p>8 = - MARKINGS C, J - MARKINGS A, F - MARKINGS B, D, G, H, I - MARKING E</p>	<p>9 = - MARKING A - MARKINGS F, G, J - MARKING E</p>
<p>10 = 90% + 10% ALUMINUM GOLD</p>	<p>12 = - MARKING A - MARKINGS B, C, D, E, F, G, H, I, J</p>	<p>11 = - MARKINGS D, F, G, J - MARKING E - MARKINGS A, H - MARKING C - MARKING B*</p>

*ADD TWO LONGITUDAL WHITE STRIPES (1 mm WIDE; SPACE 2 mm)

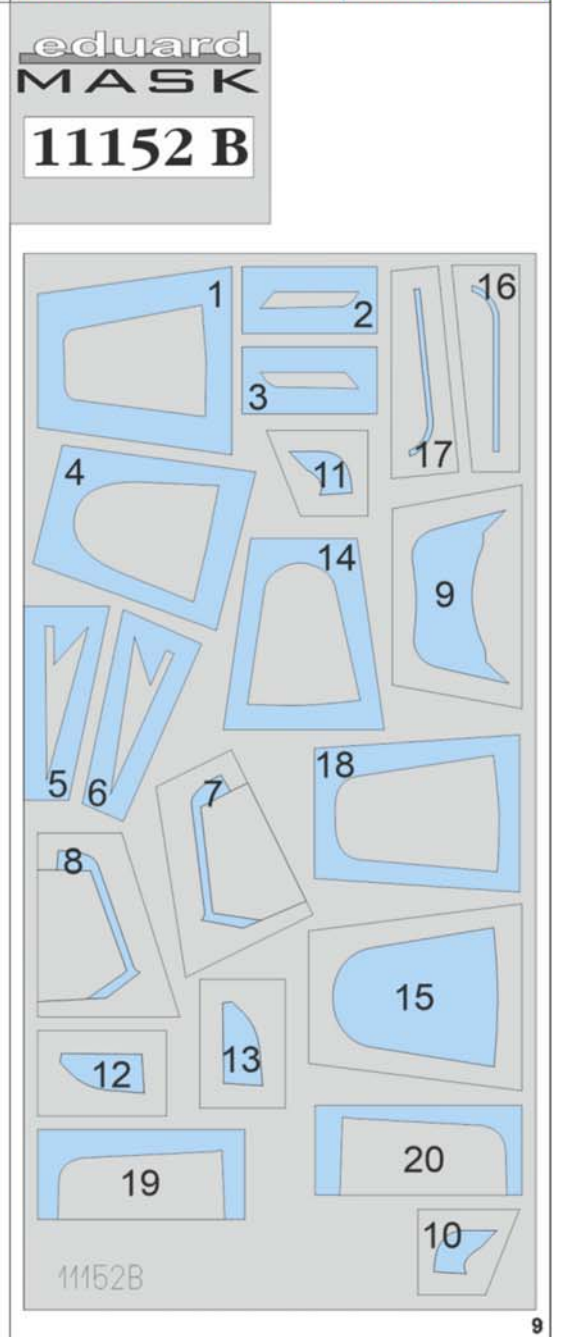
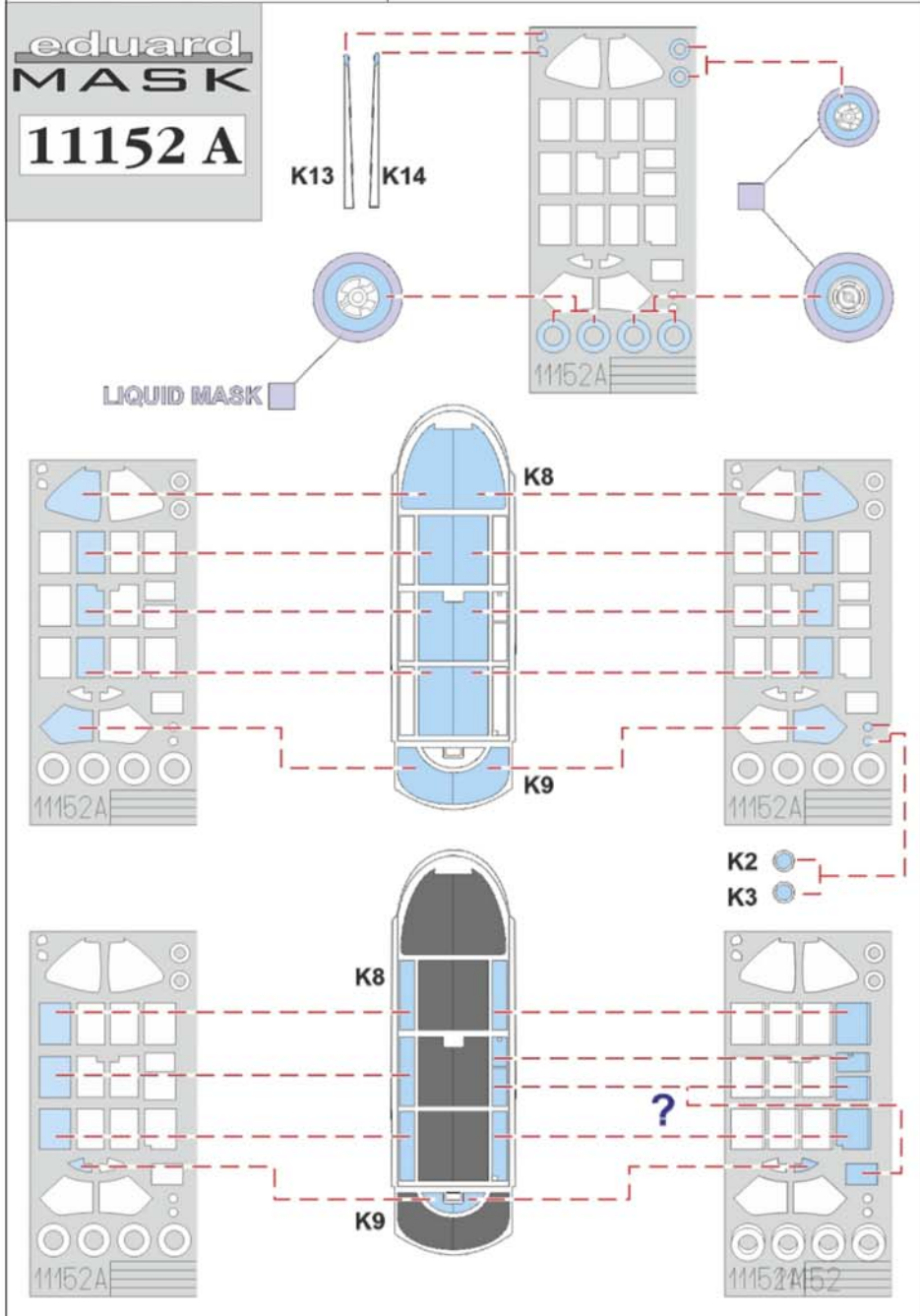

A Z-226MS, OK-KND, No. 31-09, Aero Club Chomutov, Czech Republic, 2021

One of the oldest airworthy Treners has been serving with the Chomutov Aero Club since the early 90s. It was test-flown on November 29, 1956, as the Z-226B and assigned to the Liberec County Aero Club subsequently. The Aircraft then wandered around the "subordinate" Aero Clubs like Česká Lípa, Hodkovice and Mohelkou, Raná u Loun, Most or Chomutov. Due to cracked main spar, it was deemed unairworthy in 1985 and grounded until 1990, when the overhaul was started. It was also converted to the Z-226M during the process. Later on, in December 2001, the next overhaul changed the OK-KND to Z-226MS standard. For a period of time, OK-KND was used for forest fire monitoring flights. Thanks to that, the county provided funds for the overhaul and conversion. Today, the "Kanada", as is the OK-KND nicknamed (means Canada in Czech), serves for glider towing exclusively.

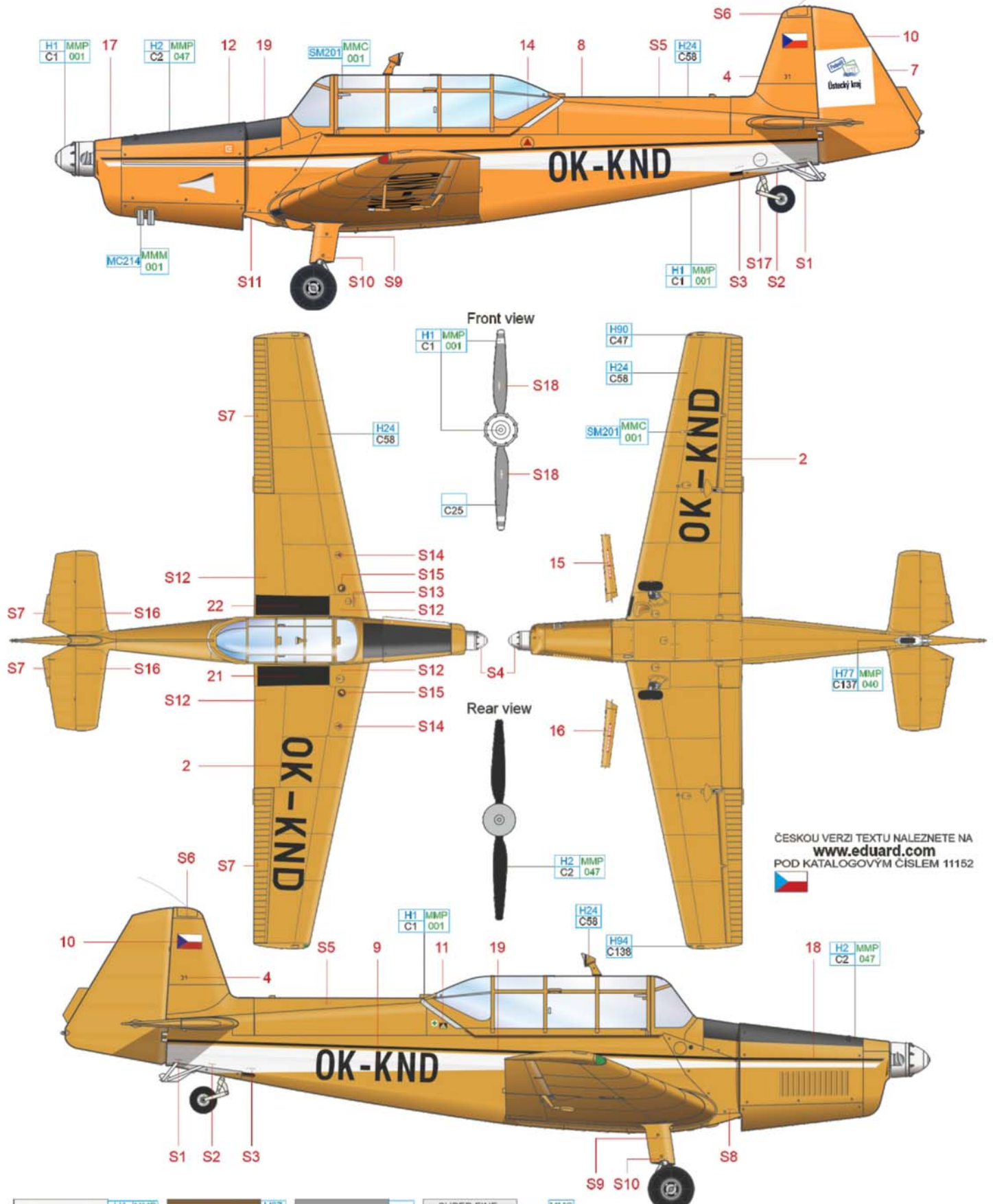

ČESKOU VERZI TEXTU NALEZNETE NA
www.eduard.com
 POD KATALOGOVÝM ČÍSLEM 11152

WHITE	H1 MMP C1 001	WOOD BROWN	H37 C43	DARK SEAGRAY	C25	SUPER FINE SILVER	SM201 MMC 001
BLACK	H2 MMP C2 047	ORANGE YELLOW	H24 C58	CLEAR GREEN	H94 C138	CLEAR RED	H90 C47
						DARK IRON	MC214 MMM 001

A1 Z-226M, OK-KND, No. 31-09, Aero Club Chomutov, Czech Republic, around 1995

This scheme depicts the "Kanada" as it flew after the overhaul in 1990-1991 made her flying again as the Z-226M version. However, not much was missing, and it wouldn't have survived the flight from the Aerotechnik company in Kunovice, where the overhaul was made, to its home at Chomutov airfield. During the flight, the engine stopped due to malfunction. Pilot Petr Švestka, however, managed to reach the Kolín airfield, where he performed successful emergency landing, thus saving valuable Trener for the Chomutov Aero Club.

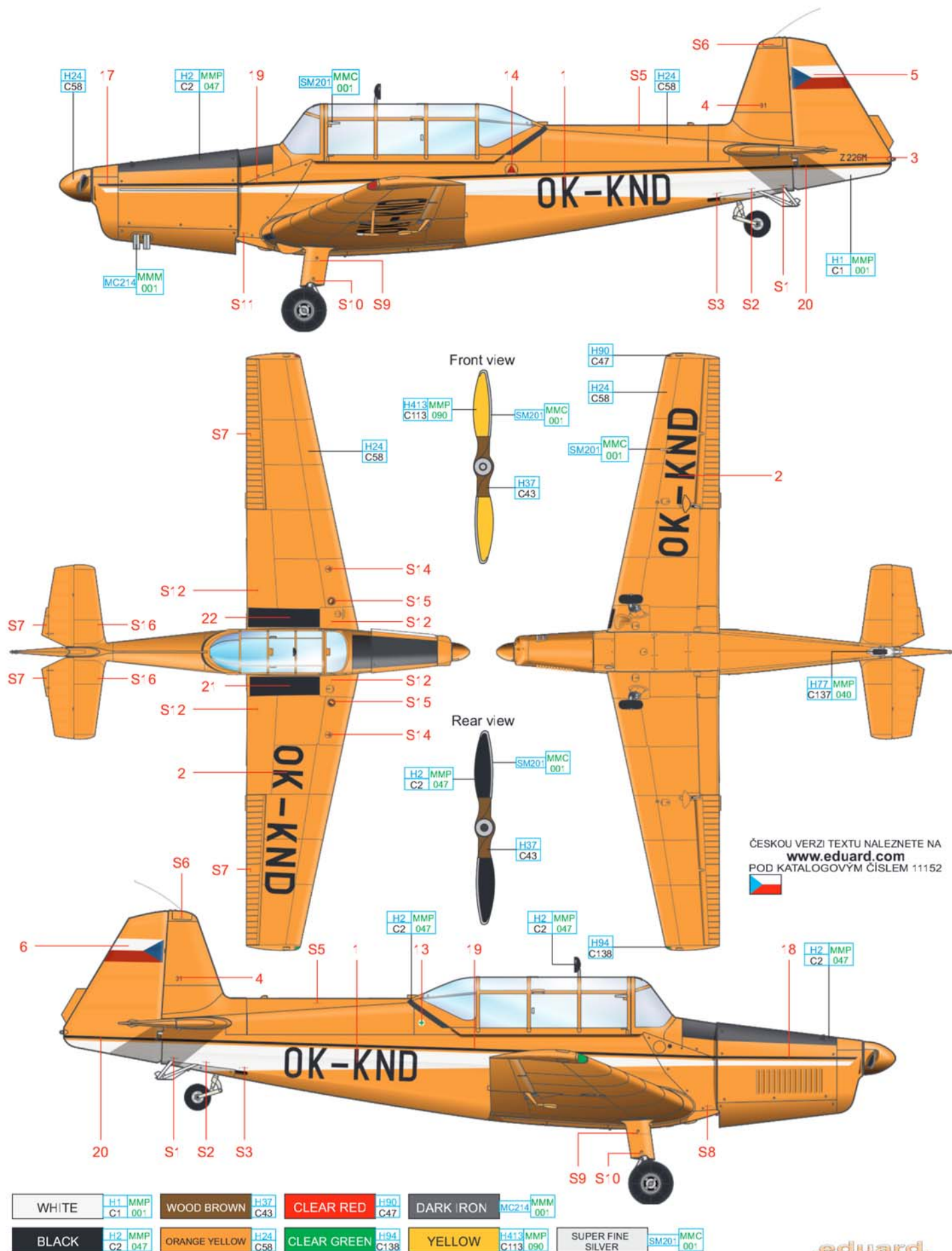

ČESKOU VERZI TEXTU NALEZNETE NA
www.eduard.com
 POD KATALOGOVÝM ČÍSLEM 11152

B Z-226MS, OK-LMG, No. 135, private owner, Rakovnik airfield, Czech Republic, 2020

This Trener was manufactured in 1957 as the Z-226T. After the engine reached its service life, the original Walter Minor 6-III engine was replaced by four-cylinder Minor 4-III (due to the shortage of six-cylinders) and the OK-LMG became the Z-126T. It was later converted to the Z-226M and then to the Z-226MS as part of further overhauls. For several years it flew at Brno-Slatina, and in 1991 it was acquired by the Aero Club Břevclav. During this period, it also changed its colors from red to blue-white combination. In 2009 the OK-LMG was sold to a group of private owners. The aircraft was given a drawing of a mouse on the port side of the fuselage, resembling the one Adolf Galland had painted on the fuselage of his Bf109s. The OK-LMG is currently "grounded" but will fly again.

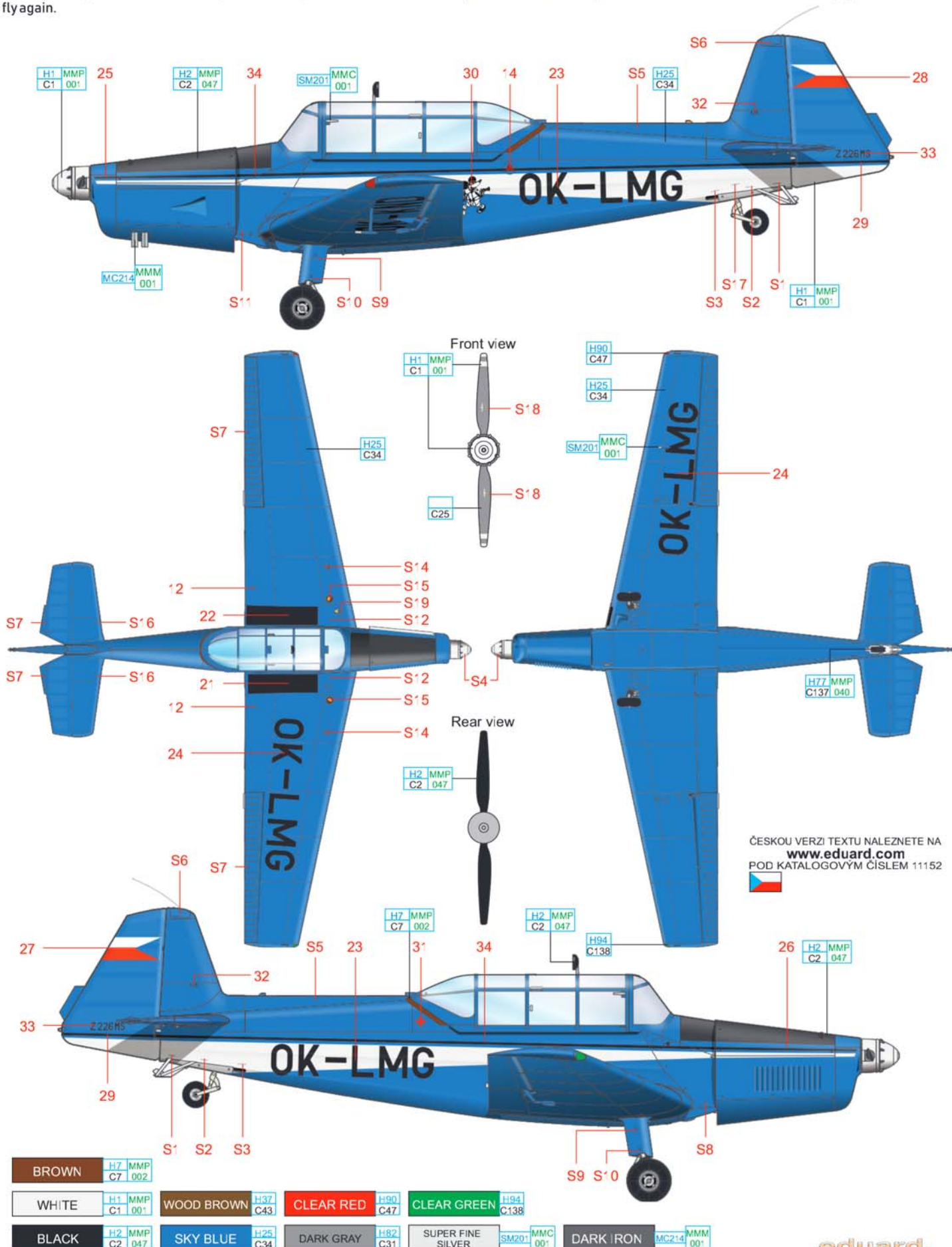

ČESKOU VERZI TEXTU NALEZNETE NA
www.eduard.com
 POD KATALOGOVÝM ČÍSLEM 11152

C Z-226T, HA-TRM, No. 369, JGTaviation, Tököl airfield, Hungary, 2021

This aircraft was manufactured in 1961 as the Z-226T and exported to Hungary in 1962 as part of the second delivery of Trainers to this country. The first owner was MHSZ (Magyar Honvédelmi Szövetség) and served with several Aero Clubs, like Borsod or Farkashegy. It was grounded on November 30, 1976 and was used as a school teaching aid for mechanics. Around 1990 the plane was brought by private owner, but stayed grounded due to lack of money. The second private owner made a general airframe overhaul in Hungary and installed an original Walter engine into the airframe. The engine was overhauled by Walter Motor Service in Prague. The complete overhaul was finished at 2001. The aircraft went through several private hands in the coming years, the present one operates it for some 15 years. It is the last Z-226T in Hungary.

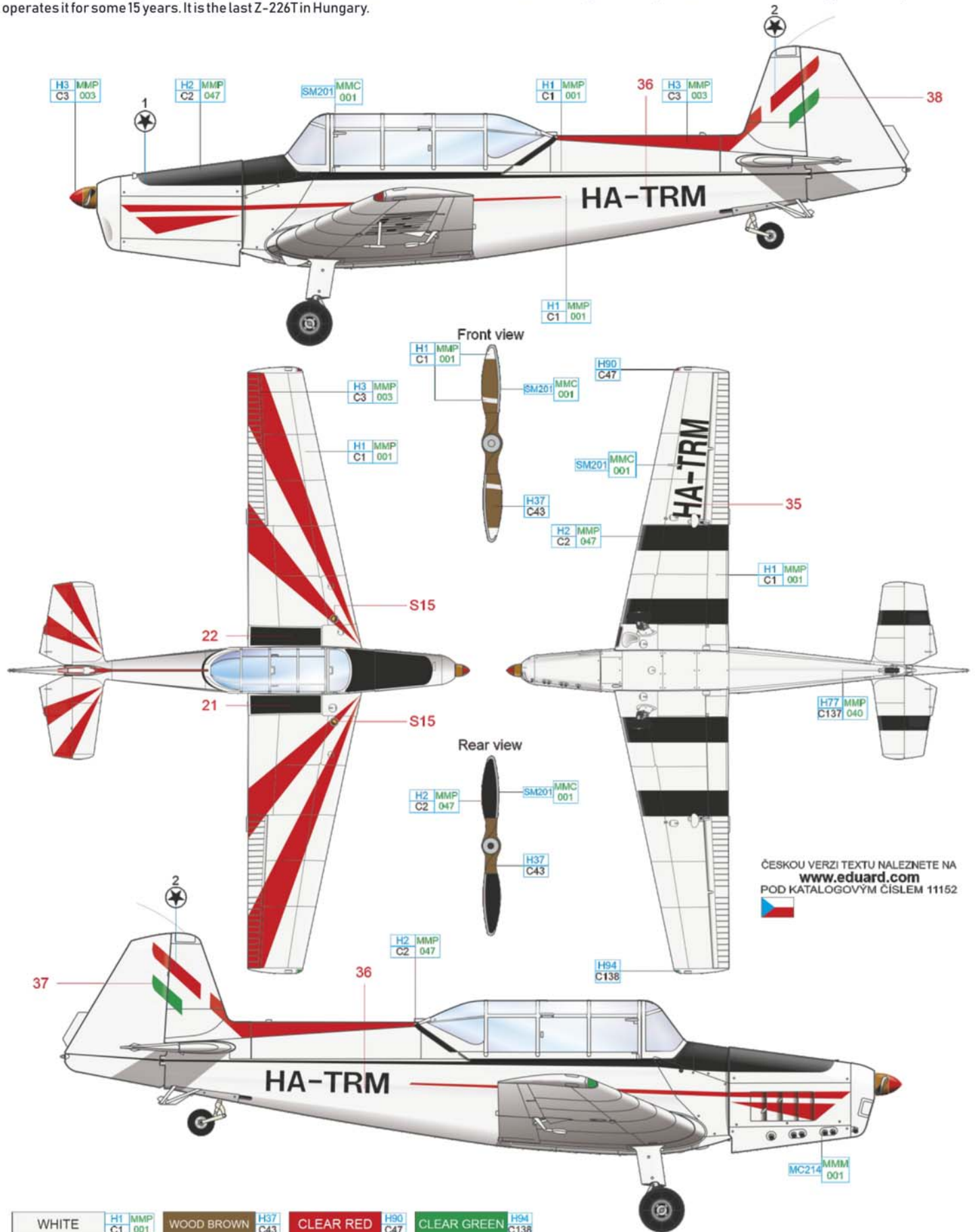

ČESKOU VERZI TEXTU NALEZNETE NA www.eduard.com
POD KATALOGOVÝM ČÍSLEM 11152



WHITE	H1 MMP C1 001	WOOD BROWN	H37 C43	CLEAR RED	H90 C47	CLEAR GREEN	H94 C138
BLACK	H2 MMP C2 047	RED	H3 MMP C3 003	SUPER FINE SILVER	SM201 MMC 001	DARK IRON	MC214 MMM 001

D Z-226T, OK-MUA, No. 370, Ladislav Bezák, Kladno airfield, Czechoslovakia, 1971

One of three private Treners in the former Czechoslovakia at the turn of the sixties and seventies was in possession of Ladislav Bezák, the first official aerobatics world champion. He assembled it personally using a discarded airframe obtained from the Kladno Aero Club and a number of scavenged parts. It was registered on October 29, 1968, with serial number 370, which, however, duplicated the factory serial number of another aircraft (HA-TRL delivered to Hungary). Bezák was flying his Trainer for aerobatics and air shows. On December 19, 1971 he used this aircraft to emigrate with his family from Czechoslovakia to the West Germany and continued to operate it under German (D-EMUD) and British (G-BEZA) registration later on. Ladislav Bezák died in 2018 and the aircraft is stored in Germany in an unairworthy condition today.



ČESKOU VERZI TEXTU NALEZNETE NA www.eduard.com POD KATALOGOVÝM ČÍSLEM 11152

E Z-226M, OK-KNM, No. 40-09, Aero Club Roudnice nad Labem, Czech Republic, 2019

This aircraft was manufactured as the Z-226B version in 1957 and converted to the Z-226M in 1983. During its long and successful operation as a towing aircraft it suffered two rather strange accidents. The first occurred on June 22, 1968 and was a very curious collision between towing Trener and towed L-13 Blaník sailplane. The OK-KNM suffered heavy damage to the tail surfaces, but pilot Bohumil Švec managed to land safely and so did the pilot of the sailplane. The second accident on June 29, 1984, was no less curious, as the L-60 with running engine started to taxi with nobody at the controls at the airfield Raná u Loun. On its way to the fire water storage tank (in which it finally ended up) the L-60 damaged the OK-KNM. It is currently grounded due to the end of the engine service life.

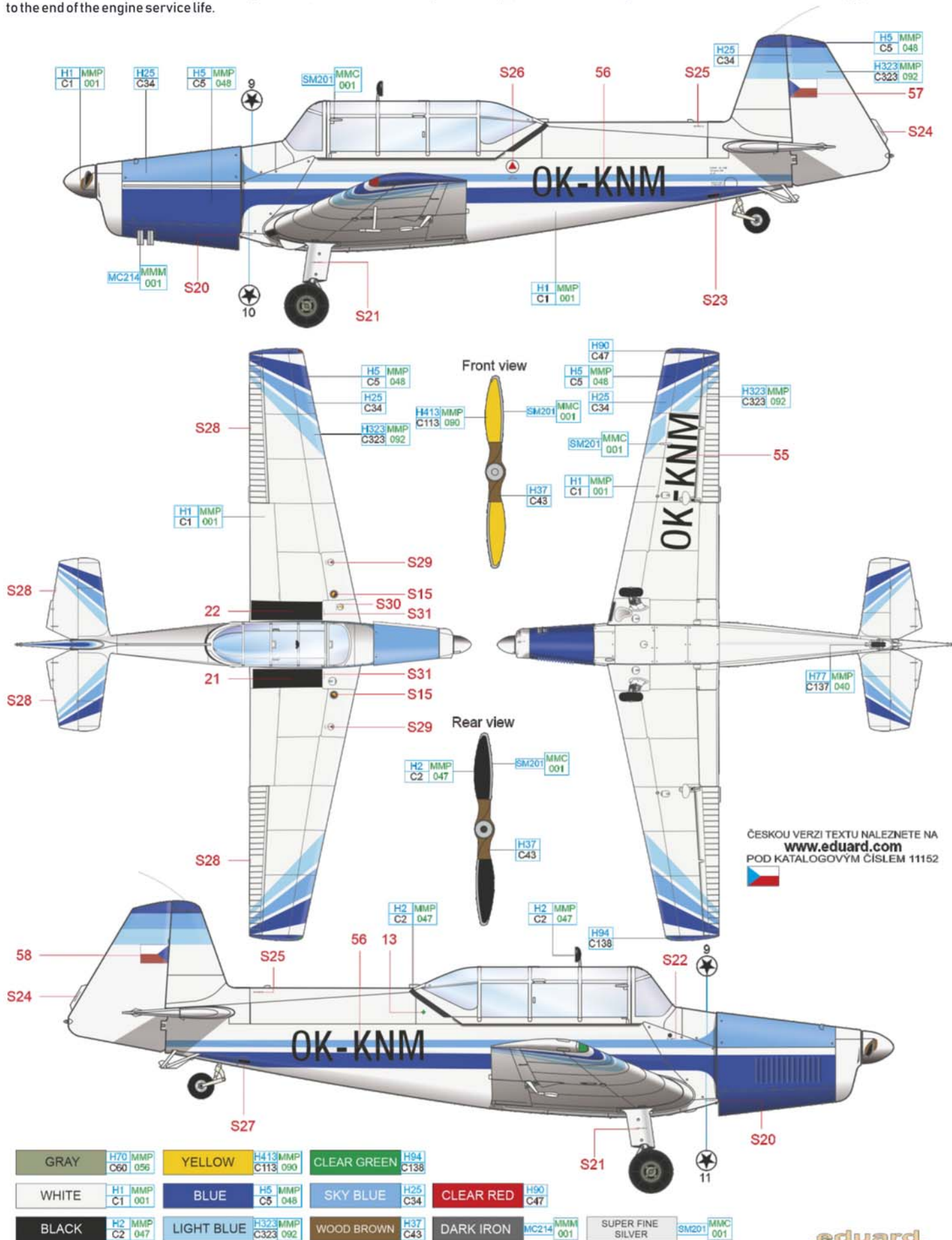

ČESKOU VERZI TEXTU NALEZNETE NA www.eduard.com
 POD KATALOGOVÝM ČÍSLEM 11152

F Z-226B, OK-MPJ, No. 255, Aero Club Kladno, Czechoslovakia, 1970s

The towing specials, Z-226B nicknamed "Bohatýr" (meaning something as a strong hero) were a welcome help to Aero Clubs. The aircraft of serial number 255 was registered in December 1958 and was operated by the Kladno Aero Club in the seventies. The standard factory livery, which for the Z-226B version consisted of a basic silver color with blue accessories, was complemented by a drawing of a "cheerful cow" by Josef Valenta, one of the Aero Club members. He went on to decorate several other aircraft with his paintings, most recently the Z-526F OK-CRA in 1998. Today, the OK-MPJ has private owners and after conversion to the Z-226MS standard, it is flying in silver livery with blue checkerboard on the nose, tail surfaces and wing.

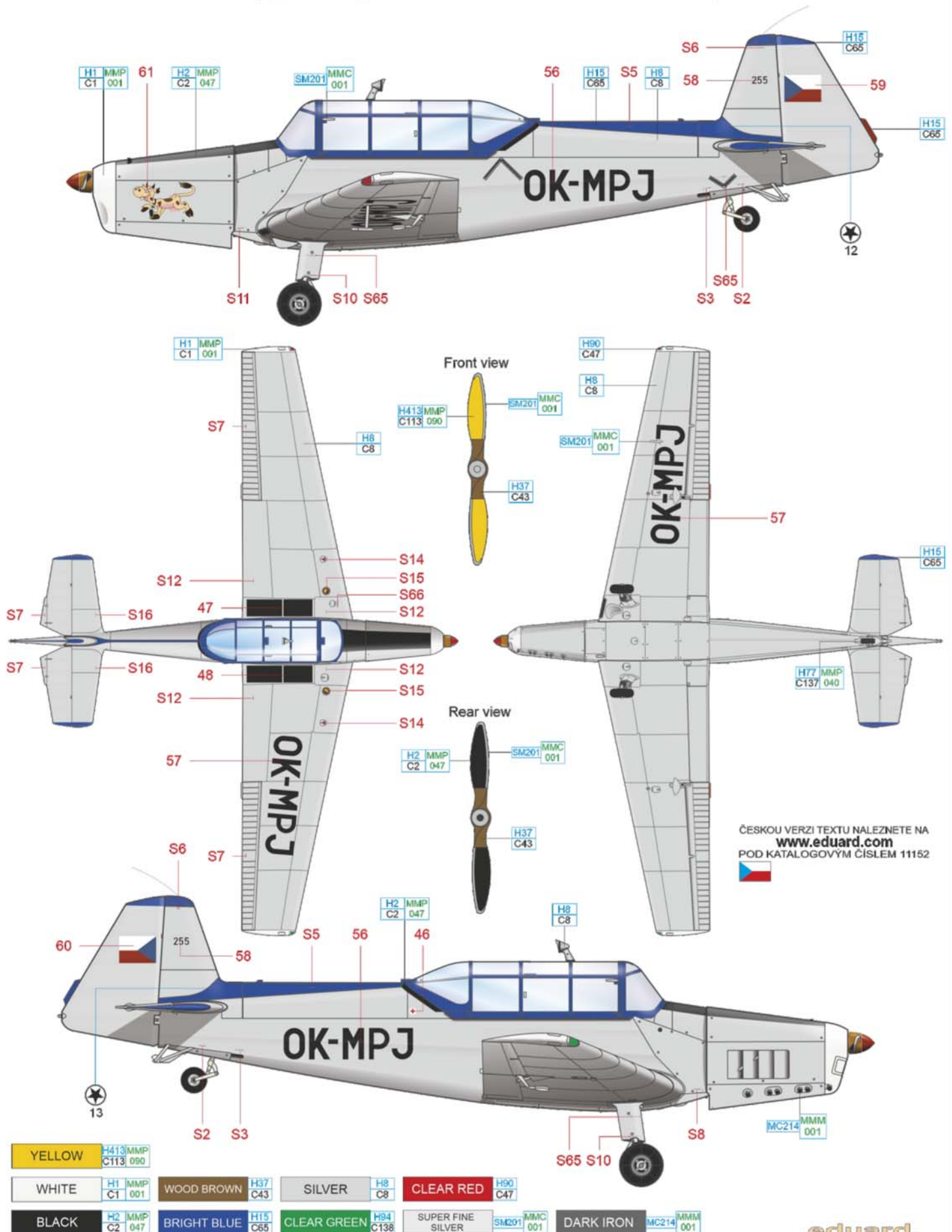

G Z-226B, OK-MQL, No. 283, Aero Club Kralupy nad Vltavou, Czech Republic, 2010

This aircraft was manufactured as a Z-226B, it has been operated as the Z-226B and still flies as the Z-226B... The aircraft of the serial number 283 was registered on April 10, 1959, and is unique because it did not undergo any conversion to different version. Incidentally, it is the last airworthy „Bohatýr“, as the Z-226B was nicknamed (meaning something as a strong hero). The OK-MQL served for many years with the Aero Club Kralupy nad Vltavou and was operated at the Sazená airfield. In 2015, it was bought by private Ikarus Gliding Club organisation and has its home at the airport in Dvůr Králové today. The colour scheme of this Trener was made by late Tomáš Skořepa in 1990.



H Z-226MS, OM-MPX, No. 264, Aero Club Nové Zámky, Slovakia, 2021

Originally manufactured as Z-226B, the aircraft was registered of the then Czechoslovakia as OK-MPX on January 9, 1959. It was operated at Prešov airfield, later used by the Aero Clubs of Holíč and Senica. In 1992 the aircraft was overhauled by Zlín-Avion Service. It was the first overhaul carried out by the company (it was founded in 1991). Since 2009, OM-MPX, already in MS version, is operated by the Aero Club Nové Zámky, where the aircraft underwent an extensive repair in 2011-2012, including the replacement of all canvas surfaces or canopy. At the same time, The OM-MPX received the current colours. On May 6, 2017, it was damaged when the pilot hit the runway demarcation sign with left wing. The wing was repaired by the Slováký Aeroklub Kunovice, but the paintwork failed to mix the exact shade of original paint, so the repaired area is clearly visible.

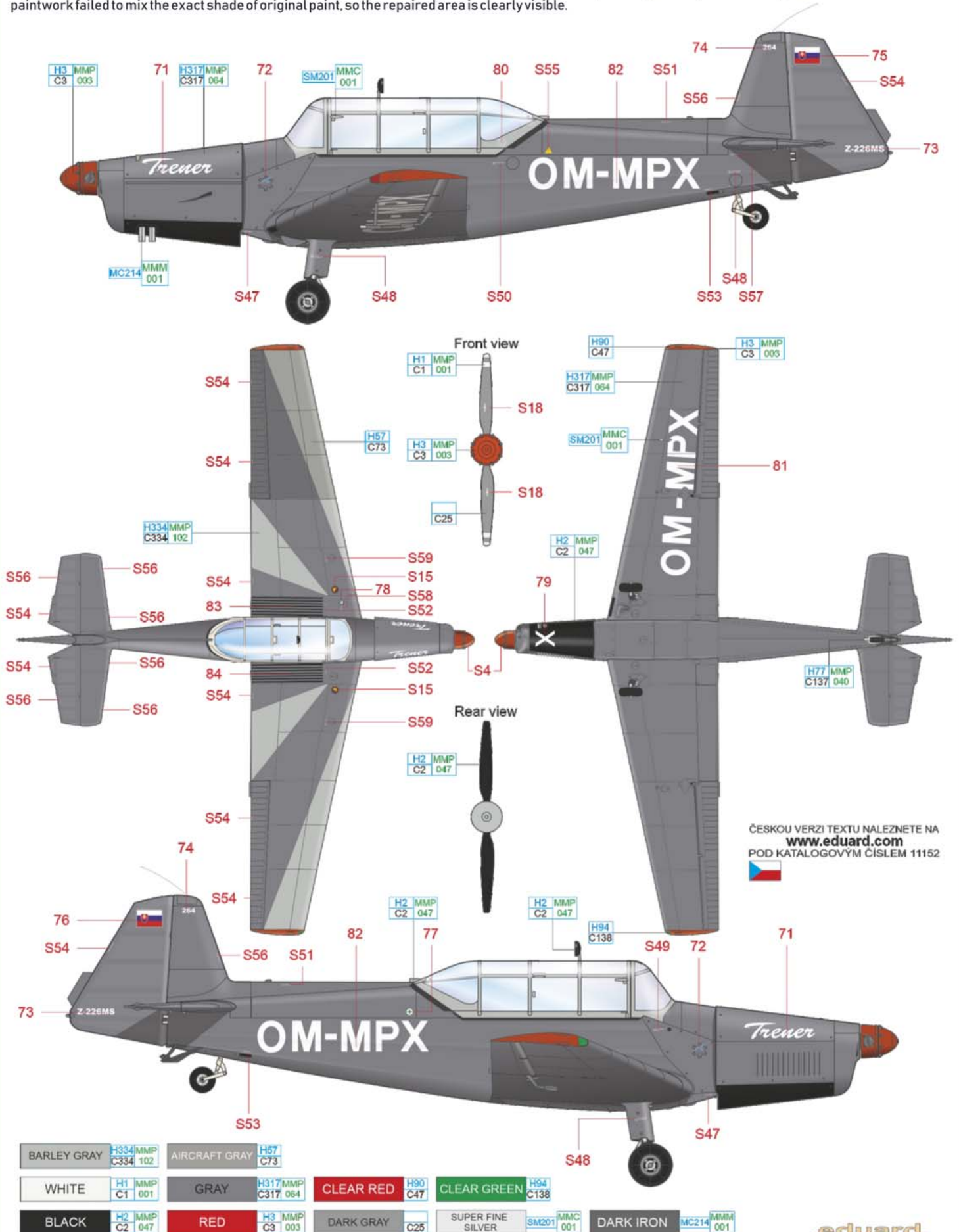

ČESKOU VERZI TEXTU NALEZNETE NA
www.eduard.com
 POD KATALOGOVÝM ČÍSLEM 11152



The aircraft of serial number 741 of Aero Club Trenčín, has a very interesting history. After the overhaul of the Treners at the Letecké opravovne Trenčín (Trenčín Aircraft Repair Works - LOTN) was discontinued in 1978, the local aero club was given "tacit approval" to choose what they needed from the parts that were to be scrapped. A number of members of the Trenčín Aero Club worked at LOTN and Boris Kauka, the then head of the Aero Club, initiated the assembly of an airworthy Trener using the donated parts. The only part missing was the fuselage, which the Trenčín team eventually obtained as a gift from Aero Club Holíč (Z-126). The fuselage was repaired by Aerotechnik (including replacement of the spar and engine mounts) and after obtaining all necessary permissions the new Z-226M flew for the first time on April 4, 1980. It is still flying today, since 1991 as a Z-226MS version.

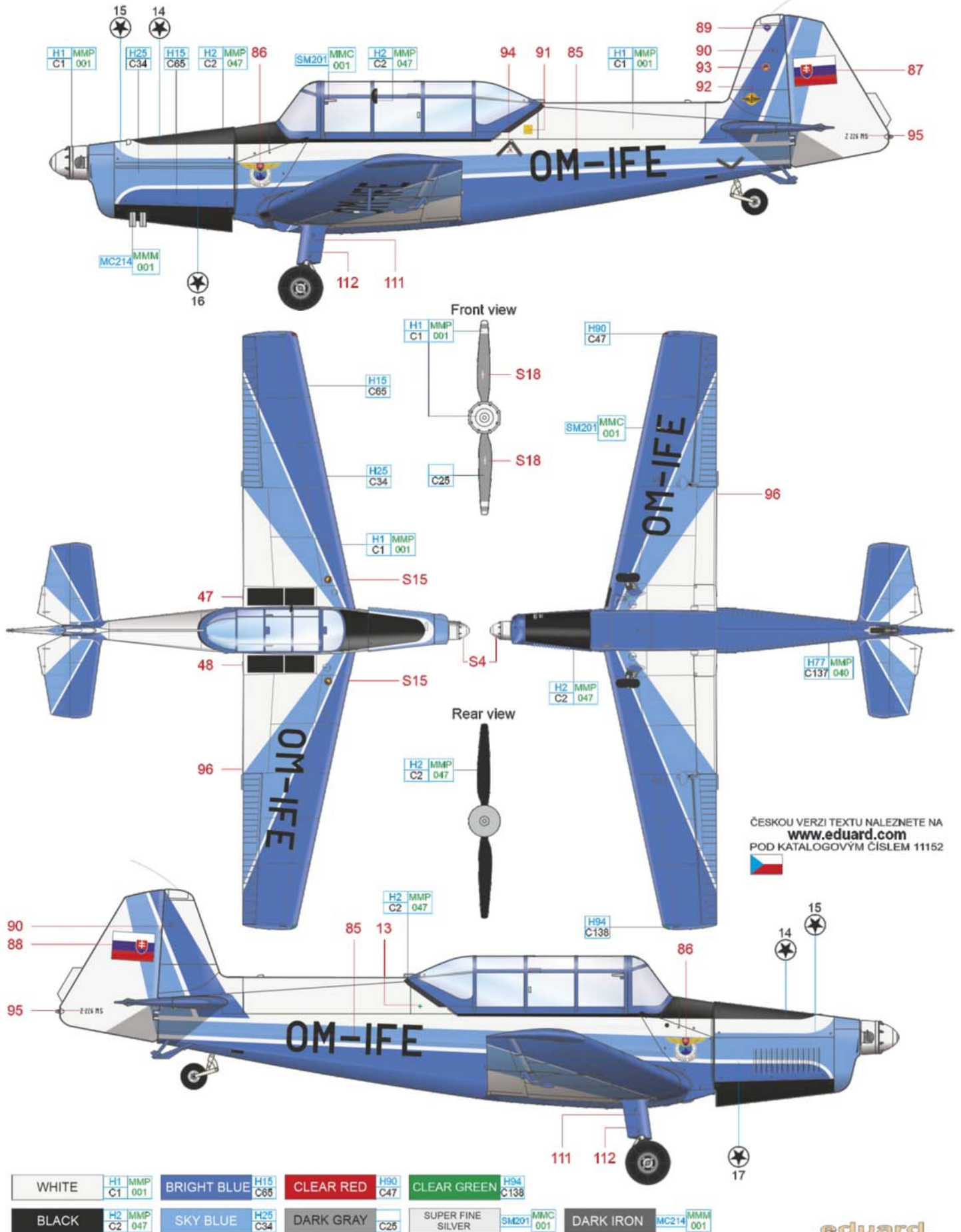

ČESKOU VERZI TEXTU NALEZNETE NA www.eduard.com POD KATALOGOVÝM ČÍSLEM 11152



